

## Request for Proposal

### Interlocal Solid Waste Authority

1. **SCOPE:** The Interlocal Solid Waste Authority (ISWA) (composed of the City of Tullahoma, Franklin County, Lincoln County, Moore County and Bedford County) is accepting proposals for the **construction of a concrete retaining wall approximately 5ft. X 18in x 80ft with a panel to allow access to the electric box and outlet at each of our 2 transfer stations. The wall shall be built as per attached drawing.** One located at 95677 Tullahoma Hwy, Estill Springs, TN and the second located at 37 Burklin St Fayetteville, TN

2. **CONCEPT:** The concept for this request is as follows:

Replacing the protective bollards at the two 2 transfer stations located at 95677 Tullahoma Hwy, Estill Springs, TN and 37 Burklin St Fayetteville, TN with a **concrete retaining wall approximately 5ft X 18in x 80ft with a panel to allow access to the electric box and outlet.** We want 3500 PSI steel fiber mix. Use 12" on center either way (OCEW). The wall must withstand daily harsh treatment from heavy equipment. **Wall shall be built as per Attached Drawing.**

You may bid on 1 or both transfer stations.

### 3. PROVISIONS

#### a. **CONDITIONS:**

1. Each Contractor shall be fully acquainted with the conditions relating to the scope and restrictions pertaining to the execution of the work under the proposal and be thoroughly familiar with the specifications.
2. The Contractor's attention is directed to the fact that all applicable State laws, municipal ordinances, and the rules and regulations of all authorities having jurisdiction over the work to be performed shall apply to the proposal throughout, and they will be deemed to be included in the Proposal as though written out in full in the Proposal.
3. The Contractor shall conduct its operations under compliance of the Tennessee Solid Waste Regulations.

#### b. **NAME, ADDRESS, AND LEGAL STATUS OF THE CONTRACTOR:**

1. The proposal must be properly signed in ink and the address of the Contractor given. The Contractor's legal status, corporation, partnership, or individual shall also be stated in the proposal.

2. A corporation shall execute the proposal by its duly authorized officers in accordance with its corporate by-laws and shall also list the state in which it is incorporated. A partnership Contractor shall give full names of all partners. Partnership and individual Contractors will be required to state in the proposal the names of all persons with an interest therein.

3. The place of residence of each Contractor, or the office address in the case of a firm or company, with county and state and telephone number, must be given after his signature. If the Contractor is a joint venture consisting of a combination of any or all of the above entities each joint venture shall execute the proposal.

4. Anyone signing a proposal as an agent of another or others must submit with his proposal the Legal evidence of his authority to do so.

- c. **COMPETENCE OF CONTRACTOR:** The opening and reading of the proposal shall not be construed as an acceptance of the Contractor as a qualified responsible Contractor. The Authority reserves the right to determine the competence and responsibility of a Contractor from its knowledge of the Contractor's qualifications or from other sources
- d. **REMEDY:** The Authority remedy for breach of contract under this Contract or failure to perform shall be any remedy provided by law.
- e. **BASIS AND METHOD OF PAYMENT:**
  - 1. Services and materials that are required pursuant to adequately complete the construction of one or both of the concrete walls, the charges shall not exceed the prices as fixed by the proposal.
  - 2. The charges provided by (1) shall include all related costs.
- f. **AUTHORITY TO ACT AS COLLECTOR:** Addressed under separate bid
- g. **CONTRACTOR BILLINGS TO AUTHORITY:** The Contractor shall bill the Authority after the successful completion of the job specified in this proposal. Payment shall be sent to contractor thirty (30) days following the end of such month. Such billing and payment shall be based on the price as set forth in the Proposal documents.
- h. **TRANSFER ABILITY OF CONTRACT:** Other than by operation of law, no assignment of the Contract or any right accruing under the express written consent of the Authority which consent shall not be unreasonably withheld, in the event of an assignment the assignee shall assume the liability of the Contractor

- i. **OWNERSHIP:** Not Applicable
- j. **INDEMNITY:** The Contractor will indemnify and save harmless the Authority, its officers, agents, servants, and employees from and against any and all suits, actions, legal proceedings, claims, demands, damages, costs, expenses, and attorneys' fees to the extent resulting from a willful or negligent act or omission of the Contractor, its officer, agents, servants and employees in the performance of the Contract; provided, however, that the Contractor shall not be liable for any suits, actions, legal proceedings, claims, demands, damages, costs expenses, and attorneys' fees arising out of the award of this Contract or a willful or negligent act of omission of the Authority, its officers, agents, servants, and employees.
- k. **LICENSES AND TAXES:** The Contractor shall obtain all licenses and permits (other than the license and permits granted by the Contract) and promptly pay all taxes.
- l. **PROPOSALS:** Proposals will be evaluated based on the best interest of the Authority and its associated governmental agencies. The decision of the Authority will be final.
- m. **CONTACT PERSON**
  - 1. All dealings, contracts, etc. between the Contractor and the Authority shall be directed to \_\_\_\_\_ from the Contractor and A. J. Williams from the Authority or designated personnel when applicable.
  - 2. The proposals submitted must be designed for the overall well-being of the Region and shall reflect no political or monetary gain for an individual or political entity.
- n. **USE OF SUBCONTRACTORS:** The Contractor must be qualified to perform the services required. If subcontractors are employed, they must be identified shall provide copies of insurance and all other requirements required by the contractor.
- o. **COPIES:** One (10) copies of the proposal shall be submitted.
- p. **STATEMENT OF QUALIFICATIONS:** Contractor shall present a statement of qualifications for this project. Financial capability will be addressed.
- q. **DEFINITIONS:** For the purpose of this proposal, the following definitions apply:
  - 1. Authority: Interlocal Solid Waste Authority as identified in Scope.

2. The Contractor: The private construction firm and its subcontractors proposing the construction of a concrete retaining wall approximately 5ft. X 18in. x 80ft. at each of our 2 transfer stations which will replace the protective bollards.

**4. SPECIAL PROVISIONS**

**a. EVIDENCE OF INSURANCE**

1. Each proposal must be accompanied by a certificate of insurance evidencing the coverage set forth, or be accompanied by a letter from an insurance company satisfactory to the Authority stating that the said insurance coverage will be furnished by it to the one submitting the proposal in the event it is the successful Contractor.

2. The Contractor shall at all times during the Contract maintain in full force the effect employer’s liability, workman’s compensation, public liability and property coverage for the provisions of the Contract. All insurance shall be by insurers and for policy limits acceptable to the Authority and before commencement of work hereunder the Contractor agrees to furnish the Authority certificates of insurance or other evidence satisfactory to the Authority to the effect that such insurance has been procured and is in force. The certificates shall contain the following express obligation:

“This is to certify that the policies of insurance described herein have been issued to the insured for which this certificate is executed and are in force at this time. In the event of cancellation of material change in a policy affecting the certificate holder, thirty (30) days prior written notice will be given the certificate holder.”

3. For the purpose of the Contract, the Contractor shall carry the following types of insurance:

<b>COVERAGES</b>	<b>LIMITS OF LIABILITY</b>
Workmen’s Compensations	Statutory
Employer’s Liability	\$500,000.
Bodily Injury Liability (Except Automobile)	\$1,000,000. each occurrence \$2,000,000 aggregate
Property Damage Liability (Except Automobile)	\$300,000 each occurrence \$300,000 aggregate
Automobile Bodily Injury Liability	\$500,000 each person \$1,000,000 each occurrence
Automobile Property Damage	\$300,000. Each occurrence
Express Umbrella Liability	\$1,000,000 each occurrence

Contractor shall stipulate any limits lower than those listed. The Authority will evaluate the limits proposed.

- b. **BOND:** Not applicable.
- c. **POWER OF ATTORNEY:** not applicable.
- d. **AWARD OF Proposal:**
  - 1. The proposal shall be deemed as having been awarded when the Authority contacts the Contractor by phone or e-mail.
  - 2. The Contractor to whom the Proposal shall have been awarded will be required to execute the job for the Authority in such form as may be mutually agreed upon and to furnish insurance certificates.
  - 3. The Contractor will be required to submit as part of the bid proposal a complete itemized list of all materials and specifications to be furnished by the Contractor to fully complete the job in this bid proposal.
  - 4. The Contractor will be required to furnish an itemized list of his equipment available for use on the proposed job or a list of the equipment that he proposes to use from the operation location from which execution of the Proposal will take place.
  - 5. The Contractor will be required to furnish a detailed list of all personnel responsible for the execution of the job proposal from the designated operation location listing their experience and qualifications.
  - 6. The Authority may require additional certified supporting data regarding the qualifications of the Contractor in order to determine whether he is a qualified, responsible Contractor, such as a copy of the latest available certified financial statement, evidence that he is capable of commencing performance as required in the Contract documents, evidence, in form and substance satisfactory to the Authority that he possesses as a going concern the managerial and financial capacities to perform all phases of the work called for in the Contract documents, and such additional information as will satisfy the Authority that he is adequately prepared to fulfill the Contract.
- e. **DISQUALIFICATIONS OF CONTRACTORS:** Although not intended to be an exhaustive list of causes for disqualification, any one or more of the following causes, among others, may be considered sufficient for disqualification of a Contractor and the refection of its proposal:

1. Evident of collusion among Contractors.
2. Lack of competency as revealed by either financial statements, experience, or equipment statements as submitted, or other factors.
3. Lack of responsibility as shown by past work, judged from the standpoint of workmanship as submitted.
4. Default on a previous contract for failure to perform.

## 5. SPECIFICATIONS

- a. Contractor is expected to complete the construction of a concrete retaining wall approximately 5ft. X 18in. x 80ft. The wall will require an access panel in order to access the fuse box and electric outlet and shall be built as per attached drawing. We want 3500 PSI steel fiber mix or better is preferred using at least 12”on center either way (OCEW). The wall must withstand daily harsh treatment from heavy equipment. This wall will replace the protective bollards. The Contractor may bid on one or both of our 2 transfer stations.
- b. Contractor shall provide all the materials, equipment and labor needed to complete the construction of a concrete retaining wall approximately 5ft X 18in x 80ft with a panel to allow access to the electric box and outlet. The wall must be able to withstand daily harsh treatment from heavy equipment. Wall shall be built as per attached drawing. This work is to be performed at the transfer station located at 95677 Tullahoma Hwy, Estill Springs, TN and/or the transfer station located at 37 Burklin St Fayetteville, TN.
- c. COMMENCEMENT DATE: ASAP
- d. EQUIPMENT: Contractor shall provide all necessary equipment.

## 6. BID INSTRUCTIONS:

- a. Proposals shall be submitted on the form provided by the Authority. All proposals must be submitted by **MARCH 13, 2018 @ 1:00 PM Central Time**. The Authority reserves the right to reject any or all proposals or waive any irregularities. Should you have questions, contact Carol Fulmer, [www.ISWArecycle.net](http://www.ISWArecycle.net) [carol@ISWArecycle.net](mailto:carol@ISWArecycle.net). No one else will answer questions for the Authority.
- b. All proposals must be sealed and clearly marked: “CONTRACTORS NAME” and “CONCRETE RETAINING WALL”
- c. Proposals are to be mailed or delivered to the following:

Interlocal Solid Waste Authority  
419 Joyce Ln  
Winchester, TN 37398

**PROPOSAL**

**Date:** \_\_\_\_\_

**Proposal of: (Name)** \_\_\_\_\_

**(Address)** \_\_\_\_\_

**(City, State, Zip)** \_\_\_\_\_

**(Telephone, fax, e-mail)** \_\_\_\_\_

This proposal is for the construction of a concrete retaining wall approximately 5ft. X 18in. x 80ft preferably using 3500 PSI steel fiber mix or better. Using 12" on center either way (OCEW) is also preferred. **The wall must have a panel to allow access to the electric box and outlet. The wall must withstand daily harsh treatment from heavy equipment. The wall shall be built as per attached drawing.** The transfer stations located at 95677 Tullahoma Hwy, Estill Springs, TN 37330 and 37 Burklin St Fayetteville, TN 37334

To: Board of Directors for Interlocal Solid Waste Authority

Gentlemen:

The attached Proposal is submitted on behalf of the undersigned bidder(s) and no others. Evidence of my (our) authority to submit the proposal is hereby furnished. The proposal is made without collusion on the part of any other person, firm, or corporation.

I (we), the undersigned bidder(s) certify that I (we) have carefully examined the bid documents and other proposed contract documents and any and all addenda thereto.

In accordance with the requirements of the bid documents, I (we) propose to furnish all necessary materials, equipment, labor, tools, and other operating requirements and will do the work necessary to skillfully and fully complete the proposed job for the following unit prices.

Bidder acknowledges receipt of the following ADDENDUM:

---

---

---

---

**Respectfully submitted,**

**Contractor(s)**

---

**Title** \_\_\_\_\_

**Address** \_\_\_\_\_

**(To be completed if a corporation)**

**Date:** \_\_\_\_\_

**Our corporation is chartered under the laws of the State of \_\_\_\_\_  
and the names, titles, and business addresses of the executives are as follows:**

**President** \_\_\_\_\_ **Address** \_\_\_\_\_

**Secretary** \_\_\_\_\_ **Address** \_\_\_\_\_



Treasurer \_\_\_\_\_ Address \_\_\_\_\_

To be completed if a partnership)

Our partnership is composed of the following individuals:

Name \_\_\_\_\_ Address \_\_\_\_\_

Name \_\_\_\_\_ Address \_\_\_\_\_

Name \_\_\_\_\_ Address \_\_\_\_\_

By signing the above proposal, I/We further agree that we will not withdraw our proposal for a minimum of 120 days.

NOTE:

1. HILTI HIT-RE 500V3 EPOXY MORTAR SYSTEM FOR ANCHORING #6 DOWEL BARS INTO EXISTING SLAB

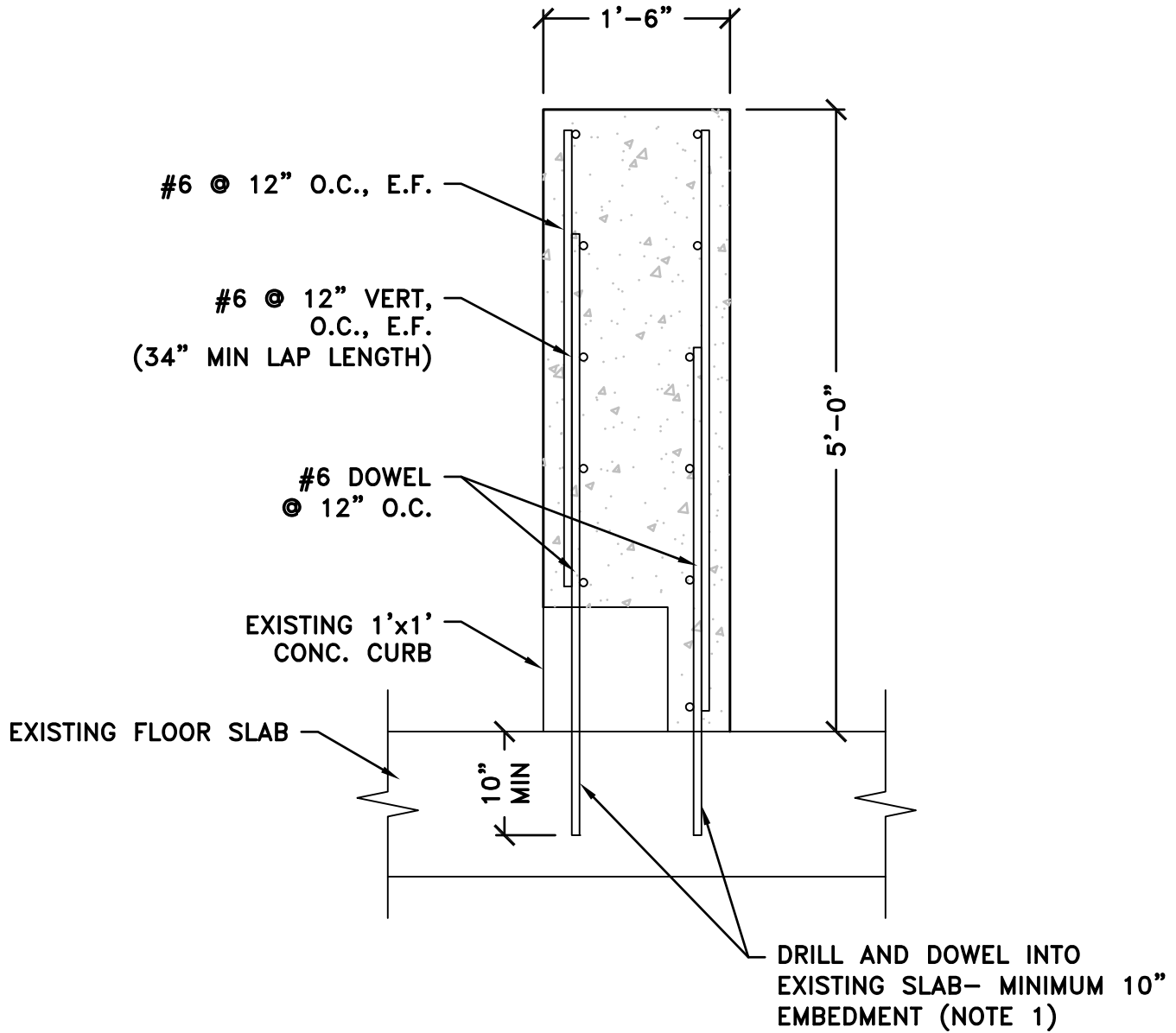

JOB

539-03

PUSH WALL DETAIL

SECRET

1.0

ESTILL SPRINGS  
TRANSFER STATION

*St. John* ENGINEERING, LLC  
ENGINEERING • PLANNING •  
ENVIRONMENTAL CONSULTING

923 JACKSON STREET  
MANCHESTER, TN 37355  
PHONE: (631) 729-2638 • FAX: (631) 729-6357  
WWW.STJOHNENGINEERING.COM

SCALE: 3/4"=1'-0"